

# HOSE REELS: 506 SERIES

50' Max hose capacity



# HOSE REELS: 506 SERIES

50' Max hose capacity



Roller arm in tank/wall mount position

## 506 Series: Single Arm Aluminum Hose Reel

Aluminum base and arms with composite spool hose reel. Reel can handle up to 50' x 1/2" hose.

### Aluminum base and guide arm

Provide the rigidity to withstand the most demanding applications while offering a reduced weight, allowing for easy installation

### Fatigue resistant steel spring

Offers years of durable performance and even load when pulling and recoiling

### Fully ported shaft and swivel

For improved flow

### Spool mounted on two permanently lubricated and sealed ball bearings

To reduce torque load on spring for smooth retraction and longer life

### Large latching area for easier operation

### Six roller guide outlet

Prevents hose pinching and reduces friction

### Hose guide arm can be placed in different positions

To accommodate any reel mounting options; floor, wall, ceiling, or tank.

### Hose reels with hose include 30" inlet hose and ball stop

### Hose reels are delivered in ceiling mount position

For reels delivered with arm in side mount position, add the suffix SM to the hose reel part number. i.e. 506 101SM



Roller arm in ceiling mount position

### MARKETS SERVED

- Car and truck dealers
- Service shops
- Fleets
- General manufacturing
- Service stations
- Quick lubes

### FLUIDS HANDLED

- Air
- Water
- Antifreeze and windshield wash solutions
- High pressure hot water
- Synthetic and mineral oils
- DEF
- Grease

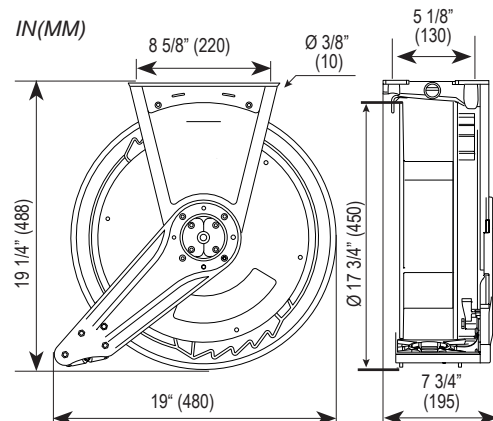

### TECHNICAL SPECIFICATIONS

#### Operating Temperature Range

Air / Water / Antifreeze	-20°F to 140° F (-20°C to 60°C)
Oil	-22°F to 194°F (-30°C to 90°C)
Grease	-22°F to 194°F (-30°C to 90°C)
DEF	-4°F to 140°F (-20°C to 60°C)

#### Wetted Parts

Air / Water / Antifreeze	Brass, acetal, nitrile rubber
Oil	Steel / electroless nickel plated steel / nitrile rubber
Grease	Steel / electroless nickel plated steel / nitrile rubber / PTFE
DEF	Stainless steel / acetal / viton

#### Weight without hose

24 lb (11 Kg)

#### Manual

850 819

### ORDER INFORMATION

Part No.	Hose Length	Hose I.D.	Outlet Thread	Max. Working Pressure	Net Weight	Reel Only With Swivel Part No.	Delivery Hose	Inlet Hose
<b>LOW PRESSURE AIR/WATER</b> antifreeze & windshield wash solution brass shaft and acetal swivel - inlet 1/2" NPT(F)								
<b>506 101</b>	30'	3/8"	1/4" NPT(M)	300 psi	26.7 lb	506 912	817	822
<b>506 121</b>	50'	3/8"	1/4" NPT(M)	300 psi	31.3 lb	506 922	820	822
<b>506 122</b>	50'	1/2"	1/2" NPT(M)	300 psi	32.8 lb	506 922	829	822
<b>LOW PRESSURE DEF</b> stainless steel shaft and acetal swivel - inlet 1/2" BSPP								
<b>506 702</b>	30'	1/2"	3/4" BSPP(M)	300 psi	28.7 lb	506 976	750 385	750 384
<b>506 722</b>	50'	1/2"	3/4" BSPP(M)	300 psi	34.1 lb	506 978	750 384	750 384
<b>MEDIUM PRESSURE OILS</b> stainless steel shaft and swivel - inlet 1/2" NPT(F)								
<b>506 202</b>	30'	1/2"	1/2" NPT(M)	2,000 psi	27.8 lb	506 920	851	845
<b>506 222</b>	50'	1/2"	1/2" NPT(M)	2,000 psi	32.8 lb	506 922	854	845
<b>HIGH PRESSURE WATER (UP TO 200° F)</b> stainless steel shaft and swivel - inlet 1/2" NPT(F)								
<b>506 421</b>	50'	3/8"	3/8" NPT(M)	2,400 psi	33.3 lb	506 942	750 325	750 323
<b>HIGH PRESSURE GREASE</b> steel shaft and swivel - inlet 3/8" NPT(F)								
<b>506 321</b>	50'	3/8"	1/4" NPT(M)	4,000 psi	35.3 lb	506 936	892 000	883

### MOUNTING BRACKET for use with 506 series hose reels in a bank. Nuts, screws and washers included.

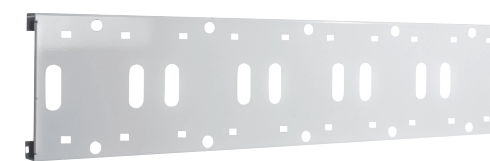

<b>360 114</b>	Holds up to two reels. Dimensions: 21 1/2" x 12"
<b>360 115</b>	Holds up to three reels. Dimensions: 32 1/2" x 12"
<b>360 117</b>	Holds up to five reels. Dimensions: 54 1/2" x 12"
<b>1390</b>	Channel mounting bracket. Channels may be mounted from I-beams with use of channel mounting brackets (up to 9" flange). Order two brackets for the two and three reel channel and three brackets for the five reel channel